

Service constraints at Thomastown (TT) Zone Substation

**Regulatory Investment Test for
Distribution**

Draft Project Assessment Report



Published: 20 July 2022

ISSUE/AMENDMENT STATUS

Issue	Date	Description	Author	Approved
1	19/07/2022	First Issue	Murtaza Latif	Shane Carr

Disclaimer

This document belongs to AusNet Services and may or may not contain all available information on the subject matter this document purports to address.

The information contained in this document is subject to review and AusNet Services may amend this document at any time. Amendments will be indicated in the Amendment Table, but AusNet Services does not undertake to keep this document up to date.

To the maximum extent permitted by law, AusNet Services makes no representation or warranty (express or implied) as to the accuracy, reliability, or completeness of the information contained in this document, or its suitability for any intended purpose. AusNet Services (which, for the purposes of this disclaimer, includes all of its related bodies corporate, its officers, employees, contractors, agents and consultants, and those of its related bodies corporate) shall have no liability for any loss or damage (be it direct or indirect, including liability by reason of negligence or negligent misstatement) for any statements, opinions, information or matter (expressed or implied) arising out of, contained in, or derived from, or for any omissions from, the information in this document.

Contact

This document is the responsibility of AusNet Services.

Please contact the indicated owner of the document with any inquiries.

Murtaza Latif
AusNet Services
Level 32, 2 Southbank Boulevard
Southbank Victoria 3006
Ph: (03) 9695 6000

Table of Contents

1	Executive Summary	5
1.1	Identified Need	5
1.2	Options considered and preferred option	6
1.3	Consultation	6
2	Background	7
2.1	Existing network	7
2.2	Customer Composition	8
2.3	Zone Substation Equipment	9
2.3.1	Primary Equipment	9
2.3.2	Secondary Equipment	9
3	Identified need	11
4	Assumptions underpinning the identified need	12
4.1	Regulatory Obligations	12
4.2	Asset Condition	13
4.3	Zone Substation Supply Capacity	14
4.4	Load Duration Curves	14
4.5	Feeder Circuit Supply Capacity	15
4.6	Load Transfer Capability	16
4.7	Station Configuration Supply Risk	16
5	Potential Credible Options	17
5.1	Option 1: Business as Usual	17
5.2	Option 2: Retire one transformer	17
5.3	Option 3: Retire one transformer and reduce residual risk through network support	17
5.4	Option 4: Use network support to defer retirement and replacement.....	18
5.5	Option 5: Replace 66kV and 22kV switchgear	18
5.6	Option 6: Replace one transformer and 66kV and 22kV switchgear.....	18
5.7	Option 7: Replace three transformers and 66kV and 22kV switchgear.....	18
5.8	Option 8: Replace 66kV and 22kV switchgear, with different staging	18
6	Economic assessment of the credible options	19
6.1	Market benefits	19
6.2	Methodology	19
6.3	Key variables and assumptions.....	21
6.4	Cost benefit analysis	22
6.4.1	Present value analysis using central estimates	23
6.4.2	Sensitivity testing and scenario analysis	24
6.5	Preferred option.....	26
6.6	Capital and operating costs of the preferred option.....	26

Service constraints at TT – Draft Project Assessment Report

7 Satisfaction of the RIT-D27

Appendix – Technical Characteristics29

 Scope of works29

1 Executive Summary

AusNet Services is a regulated Victorian Distribution Network Service Provider (DNSP) that supplies electrical distribution services to more than 745,000 customers. Our electricity distribution network covers eastern rural Victoria and the fringe of the northern and eastern Melbourne metropolitan area.

As expected by our customers and required by the various regulatory instruments that we operate under, AusNet Services aims to maintain service levels at the lowest possible cost to our customers. To achieve this, we develop forward looking plans that aim to maximise the present value of economic benefit to all those who produce, consume and transport electricity in the National Electricity Market (NEM).

Our planning approach includes the application of a probabilistic planning methodology, under which conditions often exist where some of the load cannot be supplied under rare but possible conditions, such as during extreme demand conditions or with a network element out of service. Where relevant, we also prepare, publish, and consult on a regulatory investment test for distribution (RIT-D), which further helps ensure all credible options are identified and considered, and the best option is selected.

This Draft Project Assessment Report (DPAR) is the second stage of the RIT-D consultation process to address the existing and emerging service level constraints in the Thomastown (TT) Zone Substation supply area. It follows the publication of our non-network options report, which invited non-network proponents to engage on alternatives to our preferred network solution. We did not receive any submissions in response to that report.

This DPAR has been prepared by AusNet Services in accordance with the requirements of clause 5.17 of the National Electricity Rules (NER). This DPAR complies with the requirements of Clause 5.17.4(j) of the NER, as detailed in section 7 of this document, and the AER's RIT - D application guidelines.

1.1 Identified Need

TT commenced operation as a 66/22kV transformation station in the early 1950s. Two 20/27MVA transformers were installed in the early 1960s and a third 20/30MVA transformer was installed in the late 1960s. Two 66kV and eighteen 22kV bulk oil circuit breakers were installed at this station in the 1950s and 1960s. The physical condition of some assets has deteriorated and they are now presenting an increased risk of failure.

The key service constraints at TT are:

- Security of supply risks presented by the increasing likelihood of asset failure due to the condition of the assets;
- Health and safety risks to workers presented by a possible explosive failure of bushings on a number of the assets;
- Plant collateral damage risks presented by a possible explosive failure of bushings on a number of assets;
- Environmental risks associated with insulating oil spill or fire; and
- Reactive asset replacement risks presented by the increasing likelihood of asset failure due to the deteriorating condition of the assets.

Our assessment is that works are required to address the asset-related risks in accordance with our obligations under clause 5.2 of the Electricity Distribution Code, which requires us to meet reasonable customer expectations of reliability of supply.

1.2 Options considered and preferred option

The potentially credible options that AusNet Services considers capable of meeting the identified need include:

1. Business as Usual (counterfactual)
2. Retire one transformer
3. Retire one transformer and reduce residual risk through network support
4. Use network support to defer retirement and replacement
5. Replace 66kV and 22kV switchgear
6. Replace one transformer and 66kV and 22kV switchgear
7. Replace three transformers and 66kV and 22kV switchgear
8. Replace 66kV and 22kV switchgear (as per Option 5), with different staging

Our analysis concludes that only Options 5, 6, 7 and are credible options, and the preferred option is Option 8.

1.3 Consultation

In accordance with Clause 5.17.4(k) of the NER, we request submissions on the matters set out in this DPAR. Notification of this request for submissions will also be provided to Registered Participants, AEMO, non-network providers, interested parties and persons on our demand side engagement register as required by the NER.

Submissions should be sent to ritdconsultations@ausnetservices.com.au by 15 September 2022 and telephone enquiries can be directed to Murtaza Latif on (03) 9695 6000.

Submissions will be published on AusNet Services' website. If you do not wish to have your submission published, please clearly stipulate this at the time of lodging your submission.

2 Background

2.1 Existing network

TT Zone Substation is located in the northern suburbs of metropolitan Melbourne on the same site as the Thomastown Terminal Station (TTS), approximately 15km north of Melbourne (Melway map reference 8 H11). It is the main source of electricity for the suburbs of Thomastown, Lalor, Reservoir, Kingsbury and Bundoora.

TT supplies approximately 28,600 customers, split fairly evenly with AusNet Services supplying approximately 14,100 customers and Jemena supplying approximately 14,500 customers. The load at TT is urban in nature and includes mostly residential and industrial load with some commercial loads.

The northern suburbs of Melbourne are at an elevation of 74m above sea level. TT has typical Melbourne climate with summer average maximum temperature of 26°C, winter average minimum temperature of 6°C and with extreme temperatures reaching 46°C in summer and -3°C in winter. The average rainfall is 590mm for Essendon, the nearest weather station.

TT is supplied at 66kV via two short 66kV circuits that originate from the TTS.

The location of TT within the AusNet Services distribution network is as shown below in Figure 1.

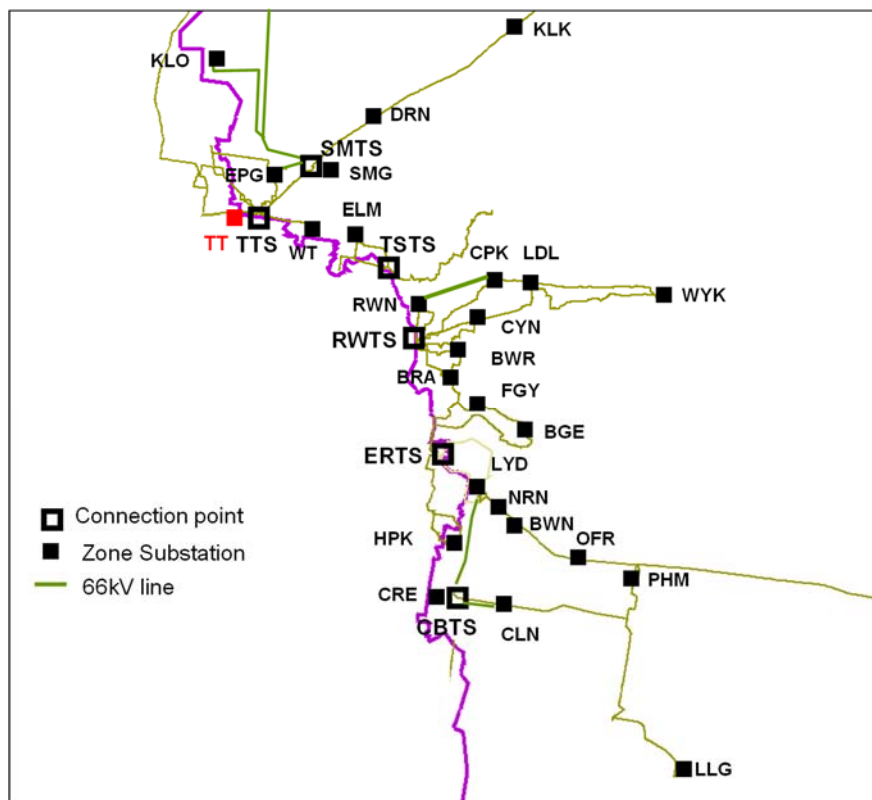

Figure 1: TT location within AusNet Services distribution network

The configuration of primary electrical circuits within TT is as shown in the following single line diagram in Figure 2 below.

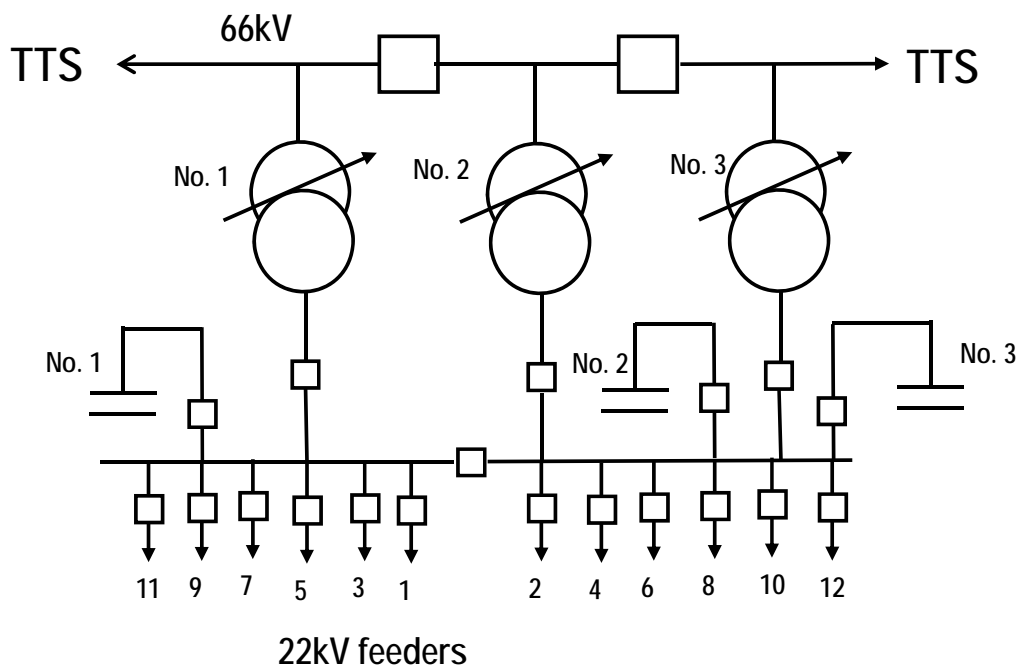

Figure 2: Single Line Diagram of TT

2.2 Customer Composition

TT has twelve 22kV feeders of which eight supply into the AusNet Services supply area and four (TT3, TT8, TT10 and TT11) supply into the Jemena electricity network area.

Table 1 provides details of the 22kV supply feeders.

Table 1: TT feeder information

Feeder	Feeder Length (km)	Feeder description	Number of Customers	Type of Customer
TT1	5.3	Summer peaking, urban feeder	200	0.5% residential 60% commercial 39% industrial 0.5% farming
TT2	7.0	Summer peaking, urban feeder	471	1.5% residential 78% commercial 20.5% industrial
TT3	-	Jemena feeder	2,893	-
TT4	9.9	Summer peaking, urban feeder	2,637	93.5% residential 5.9% commercial 0.6% industrial
TT5	10.6	Summer peaking, urban feeder	1,765	87.6% residential 11.9% commercial 1.5% industrial
TT6	23.2	Summer peaking, urban feeder	4,710	97.3% residential 2.4% commercial 0.3% industrial

Service constraints at TT – Draft Project Assessment Report

TT7	9.1	Summer peaking, urban feeder	453	2.6% residential 70.2% commercial 27.2% industrial
TT8	-	Jemena feeder	3,099	-
TT9	14.5	Summer peaking, urban feeder	3,531	94.2% residential 5.6% commercial 0.2% industrial
TT10	-	Jemema feeder	4,029	-
TT11	-	Jemena feeder	4,469	-
TT12	8.8	Summer peaking, urban feeder	342	2.0% residential 73.9% commercial 24.1% industrial

The TT 22kV feeders have open point interconnections with feeders from both Epping and Watsonia zone substations in the AusNet Services distribution network, providing a load transfer capability of 11.2MVA.

Some of the 22kV feeders have open point interconnections with feeders from both North Heidelberg (NH) and Coburg North (CN) zone substations in the Jemena distribution network, providing an additional load transfer capability of 12.5 MVA.

2.3 Zone Substation Equipment

2.3.1 Primary Equipment

TT comprises an air insulated 66kV switchyard with three 66kV buses separated by bus-tie circuit breakers. These 66kV buses are supplied by two incoming 66kV lines from TTS.

There are three 66/22kV transformers supplying two 22kV air insulated busbars, which are connected to one another with a bus tie circuit breaker. Across the two 22kV buses, there are twelve 22kV feeders and three 2X6MVA capacitor banks.

The two 66kV bus tie circuit breakers are bulk oil units which were installed in the late 1960s.

The 22kV switchyard currently has nineteen 22kV circuit breakers including eighteen bulk-oil circuit breakers installed in the late 1950s, when the station was established, and one vacuum circuit breaker that was installed in 1999 to protect the No.2 capacitor bank.

Of the three 66/22kV transformers, the No.1 and No.2 units are rated 20/27MVA and were installed in the early 1960s, while the No.3 unit is rated 20/30MVA and was installed in the late 1960s.

2.3.2 Secondary Equipment

The two incoming 66kV lines are protected by duplicated current differential protection schemes using modern numerical relays.

The 66kV bus protection is covered by duplicated High Impedance Bus protection using old electromechanical relays.

The 66/22kV transformers are protected by overcurrent protection using old electromechanical relays and transformer differential schemes employing old digital relays.

The 22kV bus protection has duplicate schemes using modern numerical relays for bus differential protection and bus distance overcurrent protection.

The 22kV feeder circuit breakers have overcurrent, earth fault, directional sensitive earth fault and auto reclose schemes provided by modern numerical relays.

Service constraints at TT – Draft Project Assessment Report

The 22kV capacitor bank protection has overcurrent, earth fault, unbalance and overvoltage schemes using modern numerical relays.

The station has two 300kVA station service transformers, and duplicated 240V AC systems and battery chargers that supply a 250V DC system for the protection relays and trip coils.

3 Identified need

TT commenced operation as a 66/22kV transformation station in the early 1950s. Two 20/27MVA transformers were installed in the early 1960s and a third 20/30MVA transformer was installed in the late 1960s. Two 66kV and eighteen 22kV bulk oil circuit breakers were installed at this station in the 1950s and 1960s. The physical condition of these assets has deteriorated and they are now presenting an increased risk of failure.

The key service constraints at TT are:

- Security of supply risks presented by the increasing likelihood of asset failure due to the condition of the assets;
- Health and safety risks to workers presented by a possible explosive failure of bushings on a number of the assets;
- Plant collateral damage risks presented by a possible explosive failure of bushings on a number of assets
- Environmental risks associated with insulating oil spill or fire; and
- Reactive asset replacement risks presented by the increasing likelihood of asset failure due to the deteriorating condition of the assets.

4 Assumptions underpinning the identified need

The purpose of this chapter is to summarise the key input assumptions that underpin the identified need described in the previous chapter.

4.1 Regulatory Obligations

In addressing the identified need, we must satisfy our regulatory obligations, which we summarise below.

Clause 6.5.7 of the National Electricity Rules requires AusNet Services to only propose capital expenditure required in order to achieve each of the following:

- (1) *meet or manage the expected demand for standard control services over that period;*
- (2) *comply with all applicable regulatory obligations or requirements associated with the provision of standard control services;*
- (3) *to the extent that there is no applicable regulatory obligation or requirement in relation to:*
 - (i) *quality, reliability or security of supply of standard control services; or*
 - (ii) *the reliability or security of the distribution system through the supply of standard control services*

to the relevant extent:

 - (iii) *maintain the quality, reliability and security of supply of standard control services, and*
 - (iv) *maintain the reliability and security of the distribution system through the supply of standard control services; and*
- (4) *maintain the safety of the distribution system through the supply of standard control services.*

Section 98(a) of the Electricity Safety Act requires AusNet Services to:

design, construct, operate, maintain and decommission its supply network to minimise as far as practicable –

- (a) *the hazards and risks to the safety of any person arising from the supply network; and*
- (b) *the hazards and risks of damage to the property of any person arising from the supply network; and*
- (c) *the bushfire danger arising from the supply network.*

The Electricity Safety act defines ‘practicable’ to mean having regard to –

- (a) *severity of the hazard or risk in question; and*
- (b) *state of knowledge about the hazard or risk and any ways of removing or mitigating the hazard or risk; and*
- (c) *availability and suitability of ways to remove or mitigate the hazard or risk; and*
- (d) *cost of removing or mitigating the hazard or risk.*

Clause 3.1 of the Electricity Distribution Code requires AusNet Services to:

- (b) *develop and implement plans for the acquisition, creation, maintenance, operation, refurbishment, repair and disposal of its distribution system assets and plans for the establishment and augmentation of transmission connections:*

Service constraints at TT – Draft Project Assessment Report

- (i) to comply with the laws and other performance obligations which apply to the provision of distribution services including those contained in this Code;
- (ii) to minimise the risks associated with the failure or reduced performance of assets; and
- (iii) in a way which minimises costs to customers taking into account distribution losses.

Under clause 5.2 of the Electricity Distribution Code, AusNet Services:

must use best endeavours to meet targets required by the Price Determination and targets published under clause 5.1 and otherwise meet reasonable customer expectations of reliability of supply.

4.2 Asset Condition

AMS 10-13 Condition Monitoring describes AusNet Services' strategy and approach to monitoring the condition of assets.

Asset condition is measured with reference to an asset health index on a scale of C1 to C5. Table 2 provides a description of the asset condition scores.

Table 2: Asset condition Score and Remaining Service Potential

Condition Score	Condition	Condition Description
C1	Very Good	Initial service condition
C2	Good	Deterioration has minimal impact on asset performance. Minimal short term asset failure risk.
C3	Average	Functionally sound showing some wear with minor failures, but asset still functions safely at adequate level of service.
C4	Poor	Advanced deterioration – plant and components function but require a high level of maintenance to remain operational.
C5	Very Poor	Extreme deterioration approaching end of life with failure imminent.

The condition of the key assets at TT is discussed in detail in the Asset Health Reports for the key asset classes such as power transformers, instrument transformers and switchgear with information on asset condition rankings, recommended risk mitigation options and replacement timeframes.

A summary of the asset condition at TT is provided in Table 3 and discussed in the following sections.

Table 3: TT Asset Condition Summary

Asset Type	Number of assets by condition score				
	C1	C2	C3	C4	C5
66kV Circuit Breakers				2	
66/22kV Power Transformers			2	1	
22kV Circuit Breakers	2	2		3	15
22kV Current Transformers		6		3	6
22kV Voltage Transformers				2	

These condition scores are then used to calculate the asset failure rates using the Weibull parameters determined for each asset class.

4.3 Zone Substation Supply Capacity

TT zone substation is a summer peaking station and the peak electrical demand reached 75.6MVA in the summer of 2017/18.

The peak demand at TT is currently forecast to increase slowly at approximately 0.4% per annum.

Figure 3 shows the forecast maximum demand and supply capacities (cyclic ratings) for TT.

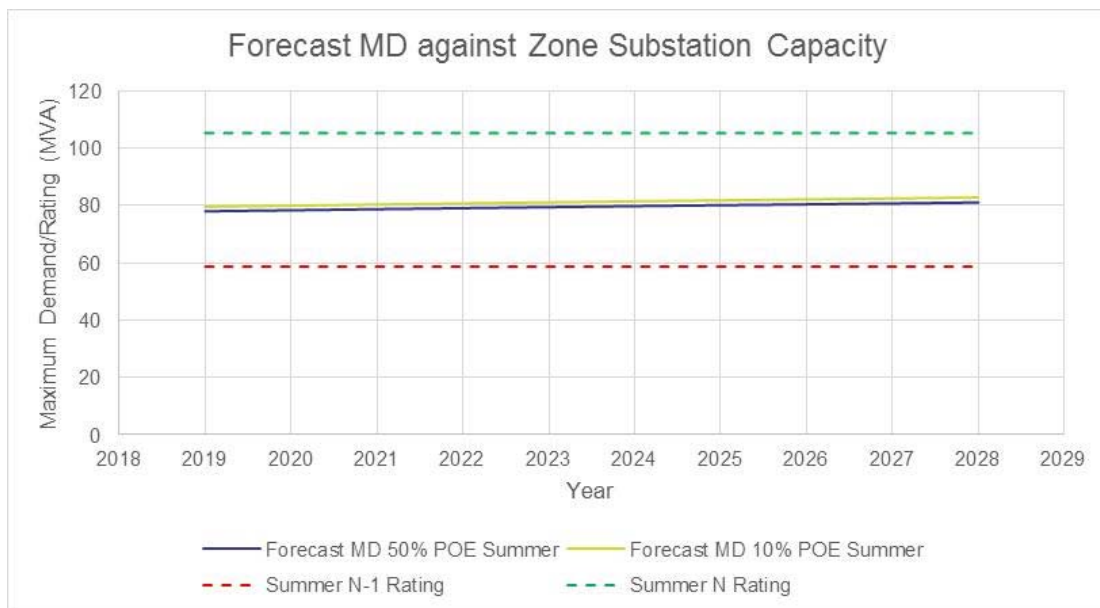

Figure 3: TT Forecast Maximum Demand against Zone Substation Capacity

4.4 Load Duration Curves

The zone substation load duration curves that feed into the risk-cost assessment model are derived from historical actual demands between:

- 1 October 2016 and 31 March 2017 for the summer 50% probability of exceedance (POE) curves;
- 1 April 2017 and 30 September 2017 for the winter 50% POE curves;
- 1 October 2013 and 31 March 2014 for the summer 10% POE curves; and
- 1 April 2017 and 30 September 2017 for the winter 10% POE curves.

The historical hourly demands are separated by season and unitised based on the recorded maximum demand within that season (summer and winter) and time period, which allows the load duration curve to be scaled according to the seasonal forecast maximum demand for each year of the assessment period.

The 50% POE unitised load duration for TT zone substation is presented in Figure 4, and the 10% POE unitised load duration for TT zone substation is presented in Figure 5.

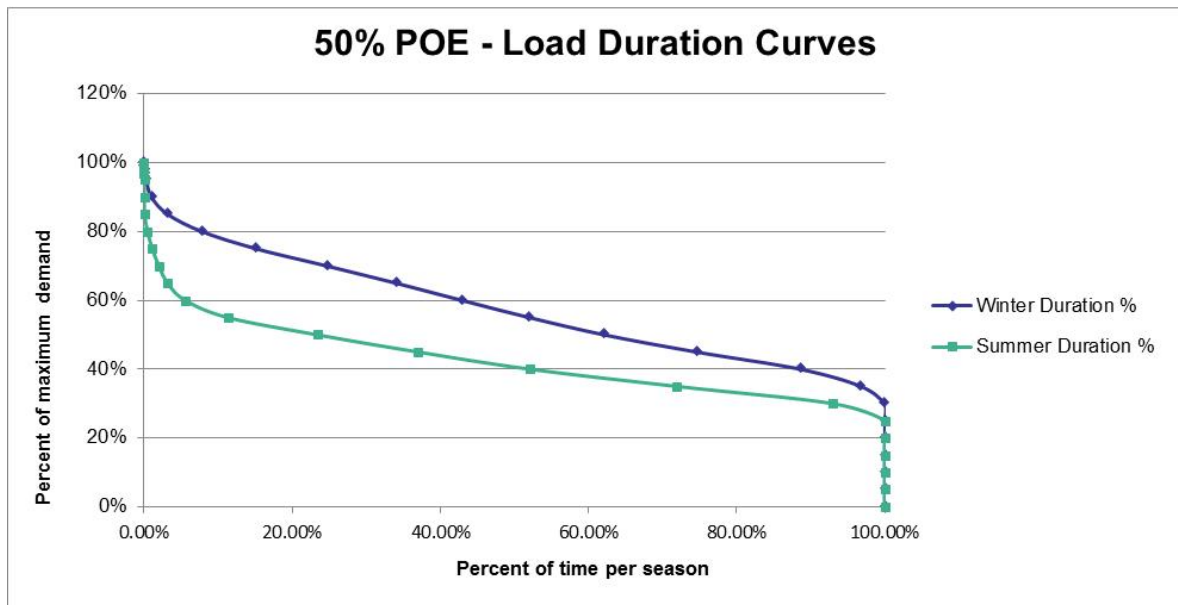

Figure 4: TT 50% POE Load Duration Curve

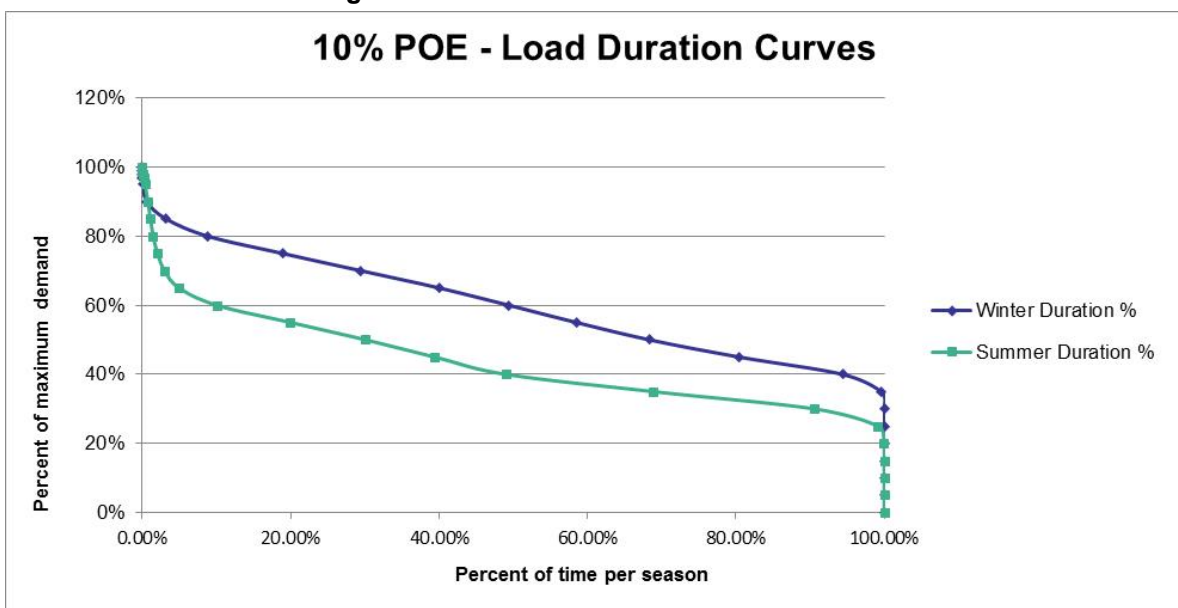

Figure 5: TT 10% POE Load Duration Curve

4.5 Feeder Circuit Supply Capacity

There is currently no requirement for additional feeders at TT due to the modest load growth expected in the area.

4.6 Load Transfer Capability

The Distribution Annual Planning Report (DAPR) provides the load transfer capability (in MW) of the feeder interconnections between TT and its neighbouring zone substations. Our forecast load transfer capability for TT is presented in Table 4.

Table 4: TT Load Transfer Capability

	2019	2020	2021	2022	2023	2024	2025	2026	2027	2028
Load Transfer Capability (MW)	23.7	23.8	23.5	23.4	23.3	23.2	23.1	23.0	22.9	22.8

4.7 Station Configuration Supply Risk

The configuration of TT means that a failure of some 22kV equipment will result in supply outages to customers as backup circuit breakers operate to isolate the failed equipment. The resultant supply outage would be for an estimated duration of two hours, which reflects the time required for operators to travel to site and manually re-configure circuits to isolate the failed equipment and sequentially restore supply to customers.

Table 5 lists the estimated bus outage consequence factors for failure of each major type of equipment based on the substation layout.

Table 5: TT Bus Outage Consequence Factors

Failed Equipment	Estimated Bus Outage Consequence
Transformer	0%
22kV circuit breaker	53%
66kV circuit breaker	0%
22kV current transformer	53%
66kV current transformer	0%
22kV voltage transformer	0%
66kV voltage transformer	0%

5 Potential Credible Options

This section outlines the potential options that have been considered to address the identified need, and summarises the key works and costs associated with implementing these options. In subsequent analysis some of these options have been found not to be credible but are nevertheless included here for completeness

The following options were considered in seeking to address the risks at TT:

1. Business as Usual
2. Retire one transformer
3. Retire one transformer and reduce residual risk through network support
4. Use network support to defer retirement and replacement
5. Replace 66kV and 22kV switchgear
6. Replace one transformer and 66kV and 22kV switchgear
7. Replace three transformers and 66kV and 22kV switchgear
8. Replace 66kV and 22kV switchgear (as per Option 5), with different staging

Each of the network options to address the identified need would need to be delivered during the 2021-25 EDPR period.

5.1 Option 1: Business as Usual

The Business as Usual (counterfactual) option assumes that AusNet Services would not undertake any investment, outside of the normal operational and maintenance processes. Under this option, increasing supply risk would be managed by increased levels of involuntary load reduction. Increased non-supply risks, such as those associated with safety, collateral damage, reactive replacement and environmental impacts, would be accepted as unmanaged rising risk costs.

The Business as Usual (counterfactual) option establishes the base level of risk, and provides a basis for comparing potential options. Whilst the direct capital and operating costs of this option are zero, the residual costs arising from this option will be significant.

5.2 Option 2: Retire one transformer

This option tests whether the current installed capacity of the substation is still required to meet customer demand and whether equipment could be retired rather than replaced.

Our analysis shows that this option would increase the expected unserved energy and would produce a negative net present value (NPV) compared to the 'Business as Usual' option. Furthermore, the retirement of one transformer would not address the asset-related risks described in the identified need. On that basis, this option is not credible and is not considered further.

5.3 Option 3: Retire one transformer and reduce residual risk through network support

This option supplements Option 2 by examining whether the addition of network support would provide a cost effective means of eliminating residual risk and therefore produce a higher net market benefit. The cost of obtaining network support will be the principal direct cost associated with this option, with capital expenditure of approximately \$130k for the associated decommissioning works and setting up a network support agreement.

The purpose of the non-network options report was to test with non-network proponents whether this option is feasible and to better understand the likely costs of procuring network support. No submissions were received from non-network proponents and, therefore, this

option is no longer considered to be credible. This option is not considered further in this DPAR.

5.4 Option 4: Use network support to defer retirement and replacement

This option extends Option 3 to consider whether sufficient network support could be provided to avoid entirely the proposed retirement and replacement of the network assets, i.e. a network support only solution.

As noted in relation to Option 3, this option will involve relatively modest direct costs to decommission assets and set up a network support agreement. The principal costs of this option is the cost of procuring network support. As we received no responses to the non-network options report, this option is no longer considered credible and is not considered further in this DPAR.

5.5 Option 5: Replace 66kV and 22kV switchgear

This option replaces the two existing 66kV circuit breakers and the existing two outdoor 22kV bus and circuit breakers with three indoor switchboards and associated secondary equipment in Stage 1. The transformers are then replaced in Stage 2 of this asset renewal proposal, scheduled for completion around 5 to 10 years after Stage 1.

The estimated capital cost of this option is \$27.30 million (real \$2022).

5.6 Option 6: Replace one transformer and 66kV and 22kV switchgear

This option replaces one of the existing transformers with a new 20/33MVA unit, replaces the two existing 66kV circuit breakers and replaces the existing outdoor 22kV bus and circuit breakers with three new indoor switchboards. It also includes replacing all associated secondary equipment.

Under this option those assets with high failure risks, including one transformer, current transformers and circuit breakers and the 22kV busses, are replaced as an integrated project.

The estimated capital cost of this option is \$30.6 million (real \$2022).

5.7 Option 7: Replace three transformers and 66kV and 22kV switchgear

This option replaces the existing transformers with three new 20/33MVA units, replaces the two existing 66kV circuit breakers and replaces the two existing outdoor 22kV buses and circuit breakers with three new indoor switchboards. It also includes replacing associated secondary equipment.

Under this option those assets with high failure risks, including transformers, current transformers and circuit breakers and the 22kV busses, are replaced as an integrated project.

The estimated capital cost of this option is \$36.5 million (real \$2022). The economic analysis in the next stage of the RIT-D will consider whether this increased capital cost is sufficiently offset by the lower residual risk associated with this option.

5.8 Option 8: Replace 66kV and 22kV switchgear, with different staging

This option is the same as option 5 with a different scope of work in each stage. In this Option 8, two existing 66kV circuit breakers would be replaced in Stage 1. Stage 2 would comprise the replacement of the existing two outdoor 22kV bus and circuit breakers with three indoor switchboards and associated secondary equipment in Stage 2.

The transformers are then replaced in next stages of this asset renewal proposal, scheduled for completion around 5 to 10 years after Stage 1.

The capital cost of this option is \$27.30 million (real \$2022)

6 Economic assessment of the credible options

6.1 Market benefits

The regulatory investment test for distribution requires the RIT-D proponent to consider whether each credible option provides the classes of market benefits described in clause 5.17.1(c)(4) of the NER. To address this requirement, the table below discusses our approach to each of the market benefits listed in clause 5.17.1(c)(4) in assessing the credible options to address the identified need at TT.

Table 6: Analysis of Market Benefits

Class of Market Benefit	Analysis
<i>(i) changes in voluntary load curtailment;</i>	The options are not expected to lead to changes in voluntary load curtailment.
<i>(ii) changes in involuntary load shedding and customer interruptions caused by network outages, using a reasonable forecast of the value of electricity to customers;</i>	The options are expected to have an impact on involuntary load shedding, although the identified need relates to asset condition. The cost benefit analysis will therefore consider the impact of each option on load shedding. AusNet Services applies probabilistic planning techniques to assess the expected cost of unserved energy for each option.
<i>(iii) changes in costs for parties, other than the RIT-D proponent, due to differences in:</i> <i>(A) the timing of new plant;</i> <i>(B) capital costs; and</i> <i>(C) the operating and maintenance costs;</i>	There is no impact on other parties.
<i>(iv) differences in the timing of expenditure;</i>	This project will not result in changes in the timing of other expenditure.
<i>(v) changes in load transfer capacity and the capacity of Embedded Generators to take up load;</i>	This project will not impact on the capacity of Embedded Generators to take up load.
<i>(vi) any additional option value (where this value has not already been included in the other classes of market benefits) gained or foregone from implementing the credible option with respect to the likely future investment needs of the National Electricity Market;</i>	This project will not impact the option value in respect to likely future investment needs of the NEM.
<i>(vii) changes in electrical energy losses; and</i>	This project will not result in changes to electrical energy losses.
<i>(viii) any other class of market benefit determined to be relevant by the AER.</i>	We do not consider any other class of market benefit as relevant to the selection of the preferred option.

6.2 Methodology

The purpose of this section is to provide a high-level explanation of our methodology for identifying the preferred option. As a general principle, it is important that the methodology takes account of the identified need and the factors that are likely to influence the choice of the preferred option. As such, the methodology is not a ‘one size fits all’ approach, but one that is tailored for the particular circumstances under consideration.

The identified need for this project can be described in terms of two types of risk:

- supply risk, where an asset failure may lead to a loss of supply to customers; and
- non-supply risk, which captures the potential consequences of an asset failure, which may include safety and environmental costs, in addition to damage to adjacent assets or property.

In relation to supply risk, we adopt a probabilistic planning methodology which considers the likelihood and severity of critical network conditions and outages. The expected annual cost to customers associated with supply risk is calculated by multiplying the expected unserved energy (the expected energy not supplied based on the probability of the supply constraint occurring in a year) by the value of customer reliability (VCR).

In relation to non-supply risks, our approach monetises this risk by multiplying the following parameter estimates:

- the probability of asset failure;
- the cost of consequence of the asset failure;
- the likelihood of the consequence given the failure has occurred; and
- the number of assets to which the analysis relates.

The purpose of the cost benefit analysis that underpins the RIT-D assessment is to determine whether there is a cost effective option to mitigate the supply and non-supply risks (the aggregate 'risk-cost'). In order to be cost effective, the reduction in the aggregate risk-cost that an option is expected to provide must exceed the cost of implementing that option. The preferred option provides greatest expected net benefit, expressed in present value terms.

- In the absence of remedial action,

Figure 6 shows how the aggregate risk-cost will typically increase as the risk of asset failure and energy at risk increase over time. The optimal timing of the preferred option occurs when the annualised capital cost of that option (or the operating cost for a non-network option) is equal to the aggregate risk-cost.

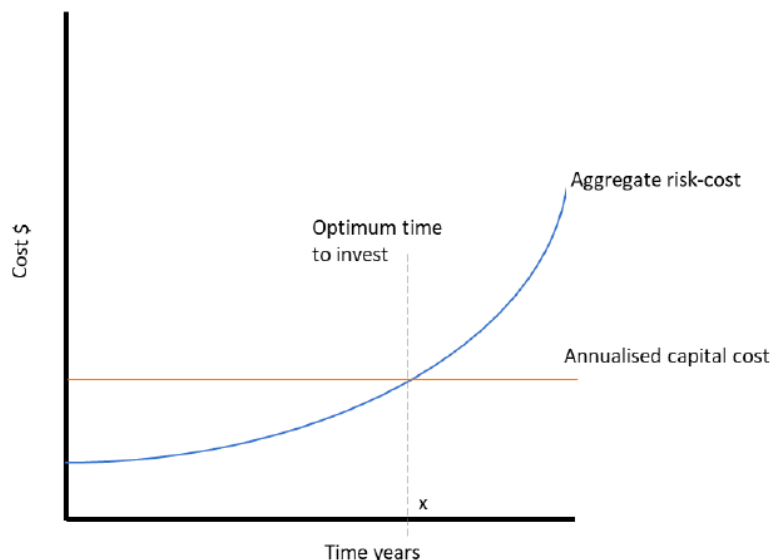

Figure 6: Increasing risk-cost over time and optimal project timing¹

¹ This figure is reproduced from the AER's Industry practice application note, Asset replacement planning, January 2019, figure 8. This figure assumes that the option eliminates the aggregate risk-cost in full, which may not be the case.

In effect, the preferred option delivers the lowest total cost to customers, which is the sum of the cost of implementing that option and any residual risk-cost. The identification of the preferred option is complicated by the fact that the future is uncertain and that various input parameters are ‘best estimates’ rather than known values. As a consequence, the RIT-D analysis must be conducted in the face of uncertainty.

To address uncertainty in our assessment of the credible options, we use sensitivity analysis and scenario analysis in our cost benefit assessment. As recommended by the AER’s application guidelines, we use sensitivity analysis to assist in determining an appropriate set of reasonable scenarios.² The relationship between sensitivity analysis and scenarios is best explained by the AER’s practice note:³

Scenarios should be constructed to express a reasonable set of internally consistent possible future states of the world. Each scenario enables consideration of the prudent and efficient investment option (or set of options) that deliver the service levels required in that scenario at the most efficient long run service cost consistent with the National Electricity Objective (NEO).

Sensitivity analysis enables understanding of which input values (variables) are the most determinant in selecting the preferred option (or set of options). By understanding the sensitivity of the options model to the input values a greater focus can be placed on refining and evidencing the key input values. Generally the more sensitive the model output is to a key input value, the more value there is in refining and evidencing the associated assumptions and choice of value.

Scenario and sensitivity analyses should be used to demonstrate that the proposed solution is robust for a reasonable range of futures and for a reasonable range of positive and negative variations in key input assumptions. NSPs should explain the rationale for the selection of the key input assumptions and the variations applied to the analysis.

In applying sensitivities and scenarios to our cost benefit assessment, we have regard to the particular circumstances to ensure that the approach is appropriate. Where our analysis shows that an option is clearly preferred, we will not undertake further testing. This approach is consistent with clause 5.17.1(c)(2) of the Rules, which states that the RIT–D must not require a level of analysis that is disproportionate to the scale and likely impact of each credible option considered.

In preparing the RIT-D, we have also had regard to AEMO’s 2021 Inputs, Assumptions and Scenarios Report and its 2022 Integrated System Plan (ISP). We note that the scenarios adopted by AEMO are focused particularly on the matters that are relevant to major transmission investments, rather than distribution investments of the type considered in this report. Accordingly, we have adopted an approach that is appropriate to the particular circumstances described in this report relating to the identified need and the credible options.

6.3 Key variables and assumptions

Table 7 below lists the key variables and assumptions applied in the economic assessment, which are essential inputs to our methodology described above. The table also sets out the upper and lower bounds of the range of forecasts adopted for each of these variables. As explained above, the lower bound and upper bound estimates are used to undertake sensitivity testing and scenario analysis. The detailed results of this modelling is provided in section 6.4.

² AER, Application guidelines, Regulatory investment test for distribution, December 2018, page 42.

³ AER, Asset replacement planning, January 2019, page 36.

Table 7: Key variables and assumptions (\$M)

Variable / assumption	Lower bound	Central estimate	Upper bound
Demand forecasts	5% reduction in central estimate of annual growth rate	Average annual growth rate of 0.4%	5% increase in central estimate of annual growth rate
Cost of involuntary supply interruption	25% reduction in central estimate	Value of Customer Reliability (VCR) of \$44,389 per MWh ⁴	25% increase in central estimate
Safety cost	Central Estimate	Value of statistical life of \$4.5 million ⁵	Central estimate
Safety cost Disproportionate Factor	Central estimate	Factor of 3	Central estimate
Option cost	15% reduction in central estimate	In-house cost estimates using detailed and high-level project scopes	15% increase in central estimate
Real discount rate per annum⁶	2.0%	5.5%	7.5%
Probability of asset failure	25% reduction in central estimate	Historical asset performance data, plus forecasts based on condition monitoring and CBRM modelling	25% increase in central estimate

Source: AusNet Services, TT_V8.0_Economic_Model-Master_Template 14-07-22

6.4 Cost benefit analysis

The economic analysis presented below allows comparison of the economic cost and benefits of each option to rank the options and to determine the optimal timing of the preferred option. It quantifies the capital costs and the cost of the residual risk for each option, to determine a total cost for each option. The net economic benefit for each credible option is the total cost associated with that option minus the costs of the 'Business as Usual' option.

As each of the credible options involves the replacement of existing assets, we have assumed that the operating cost for each option is unchanged from the 'Business as Usual' option. For the purpose of this RIT-D, we consider this approach to be a reasonable working assumption. The capital cost for each option has been described in section 5 of this DPAR.

We present our analysis as follows:

⁴ Calculated using the latest VCR estimates for each sector, refer to model 'Inputs – Global' tab.

⁵ Best Practice Regulation Guidance Note Value of statistical life, December 2014, escalated, refer to model 'Inputs – Global' tab.

⁶ The discount rates are consistent with AEMO's 2021 Inputs, Assumptions and Scenarios Report.

Service constraints at TT – Draft Project Assessment Report

- Section 6.4.1 presents the NPV analysis using central estimates; and
- Section 6.4.2 presents the sensitivity testing and scenarios analysis.

6.4.1 Present value analysis using central estimates

Table 8 presents the annualised net economic benefit of each credible option for each year and highlights the option with the highest net economic benefit, assuming the central estimates for the key variables presented in the previous section. For each option, we have selected the optimal timing or indicated for some options that the solution will not deliver a net benefit over the study period.

It should be noted that a residual risk-cost and benefit also applies for each option, which captures the costs and benefits beyond 2031. We have not shown the residual costs and benefits for each option in the table below, but it is considered in our PV analysis which is reported later in this section.

Table 8: Annualised net economic benefit (\$M)

	2022	2023	2024	2025	2026	2027	2028	2029	2030	2031
Option 1	0.0	0.0	0.0	0.0	0.0	0.0	0.0	0.0	0.0	0.0
Option 2	This option is no longer considered credible, as explained in section 5.2									
Option 3	This option is no longer considered credible, as explained in section 5.3.									
Option 4	This option is no longer considered credible, as explained in section 5.4.									
Option 5	0.000	2.220	2.601	3.017	3.470	3.974	4.523	5.106	5.728	6.317
Option 6	0.000	2.157	2.564	3.011	3.507	4.068	4.690	5.359	6.086	6.747
Option 7	0.000	1.889	2.309	2.771	3.286	3.873	4.527	5.237	6.012	6.717
Option 8	0.000	2.530	2.912	3.327	3.781	4.285	4.834	5.417	6.038	6.628

Source: AusNet Services, TT_V8.0_Economic_Model-Master_Template 14-07-22

As explained in the table above, Options 2, 3 and 4 are no longer considered to be credible options and are not considered further in this RIT-D assessment. Of the remaining options, Option 8 provides greater net benefits in each year to 2029, beyond which Option 6 provides slightly higher net benefits.

While the above table is useful in understanding how the options compare with one another in the early years following their implementation, the analysis required by the RIT-D must consider the relative performance of the credible options over the life of the asset. Accordingly, the following table shows that the present values for each option over its life, using our central estimates, based on the optimal timing for each option.

Table 9: Net economic benefit (\$M)

	PV of risk reduction Benefit	PV of Option costs	PV of net economic benefit
Option 1	0.0	0.0	0.0
Option 2	Not a credible option		
Option 3	Not a credible option		
Option 4	Not a credible option		
Option 5	\$110.53	\$26.33	\$84.20
Option 6	\$118.37	\$29.50	\$88.87
Option 7	\$122.50	\$35.18	\$87.32
Option 8	\$110.53	\$21.38	\$89.15

Source: AusNet Services, TT_V8.0_Economic_Model-Master_Template 14-07-22

The present value analysis shown in Table 9 shows that Option 8 is preferred to the remaining credible options and the 'Business as Usual' option because it delivers the highest expected net benefit over the expected life of the investment, based on our central estimates.

6.4.2 Sensitivity testing and scenario analysis

As explained in section 6.2, we undertake sensitivity testing to examine how the net benefit for each option would be affected if certain parameters were varied. In this instance, we considered variations in the risk of asset failure; demand; the cost of each option; and the discount rate. The results of this analysis is presented below.

Table 10: Net benefit - sensitivity testing (\$M)

	High asset failure	Low asset failure	High demand	Low demand	High option cost	Low option cost	High discount rate	Low discount rate
Option 1	0.0	0.0	0.0	0.0	0.0	0.0	0.0	0.0
Option 2	Not a credible option							
Option 3	Not a credible option							
Option 4	Not a credible option							
Option 5	162.20	31.44	93.23	75.56	80.25	88.15	56.32	129.42
Option 6	176.17	31.32	102.14	77.19	84.44	93.29	58.86	137.59
Option 7	178.42	27.56	102.51	74.35	82.04	92.59	56.20	137.84
Option 8	167.15	36.40	98.19	80.52	85.95	92.36	62.66	132.80

Source: AusNet Services, TT_V8.0_Economic_Model-Master_Template 14-07-22

Service constraints at TT – Draft Project Assessment Report

The sensitivity analysis shows that Option 8 provided the highest net benefit in half the cases where parameter assumptions are varied. In the remaining cases, Option 7 performed best in 3 cases. To test our results further, we have adopted four scenarios, as set out below.

Table 11: Definition of reasonable scenarios

Scenario	Probability of failure	Option Cost	Forecast Demand	VCR	Discount rate
Central Case	Central estimate	Central estimate	Central estimate	Central estimate	Central estimate
Low demand	Central estimate	Central estimate	Lower bound	Central estimate	Central estimate
Weak economic growth	Central estimate	Lower bound	Lower bound	Central estimate	Lower bound
High demand	Central estimate	Upper bound	Upper bound	Central estimate	Upper bound

Table 12 below provides a brief description of each scenario.

Table 12: Guide to scenarios

Scenario	Description
Central Case	This scenario adopts the central estimate for each variable in the economic assessment. It represents the most likely outcome.
Low demand	This scenario represents low demand driven by an increase in distributed energy resources. We have retained the other parameters at their central estimates, noting that the scenario is not driven by weak economic growth.
Weak economic growth	This scenario reflects weak economic growth, possibly as a result of the continuing impact of COVID-19. It has lower costs of delivering the option, lower demand and a lower discount rate
High demand	This scenario represents an economic rebound and continuing supply side issues. It is characterised by higher costs of delivering the option, higher demand and an upper bound discount rate.

Table 13: Net benefit for each scenario (\$M)

	Central case	Low demand	Weak economic growth	High demand
Option 1	0.0	0.0	0.0	0.0
Option 2	Not a credible option			
Option 3	Not a credible option			
Option 4	Not a credible option			
Option 5	84.20	75.56	79.31	90.72
Option 6	88.87	77.19	81.40	99.22

Service constraints at TT – Draft Project Assessment Report

Option 7	87.32	74.35	79.40	98.79
Option 8	89.15	80.52	83.52	96.42

Source: AusNet Services, TT_V8.0_Economic_Model-Master_Template 14-07-22

On the basis of this scenario analysis, Option 8 is preferred to the other options, as it delivers a higher net economic benefit across in three of the four scenarios.

6.5 Preferred option

The results of our cost benefit analysis is that Option 8 is the preferred option, which involves the following works:

- replace two 66 kV circuit breakers and associated primary and secondary assets in poor condition; and
- replace all 22 kV assets within the substation.

The preferred option is to complete this work in two stages. Stage 1 will replace two existing 66kV circuit breakers and Stage 2 will comprise the remaining scope of work. Stage 2 will be completed 5-10 years after Stage 1, with the works currently planned for completion in 2030.

The total capital cost of this option is \$27.30 million (real \$2022)

This option is expected to maximise the present value of the net economic benefit to all those who produce, consume and transport electricity in the NEM.

6.6 Capital and operating costs of the preferred option

The direct capital expenditure for the preferred option is \$22.56 million (real \$2022), excluding management reserve and capitalised overheads, as shown in the table below.

Table 14: Summary of capital expenditure requirements, \$2022

PROJECT EXPENDITURE FORECASTS		STAGE 1	STAGE 2	COMBINED
1	DESIGN	\$750,000	\$1,200,000	\$1,950,000
2	INTERNAL LABOUR	\$654,906	\$824,644	\$1,479,550
3	MATERIALS	\$1,498,620	\$6,508,140	\$8,006,760
4	PLANT & EQUIPMENT	\$371,577	\$715,813	\$1,087,390
5	CONTRACTS	\$3,411,651	\$4,740,144	\$8,151,794
7	OTHER - RISK ALLOWANCE	\$524,095	\$1,358,777	\$1,882,872
8	PROJECT DIRECT EXPENDITURE P(50)	\$7,210,849	\$15,347,518	\$22,558,366
9	OVERHEADS	\$815,547	\$1,735,804	\$2,551,351
10	FINANCE CHARGES (IDC)	\$259,572	\$786,492	\$1,046,064
11	PROJECT DIRECT EXPENDITURE (SAP)	\$8,285,968	\$17,869,814	\$26,155,782
12	MANAGEMENT RESERVE [P(90)-P(50)]	\$307,564	\$839,145	\$1,146,709
13	TOTAL EXPENDITURE FOR APPROVAL (Including P(90) Risk)	\$8,593,531	\$18,708,959	\$27,302,490

Source: AusNet Services.

The operating expenditure associated with this option will relate to the on-going inspection and maintenance of the assets. Our assessment is that a reasonable estimate of the annual operating expenditure is approximately 1.2% of the direct capital cost of the asset, which equates to approximately \$270k per annum.

In relation to the timetable for completing these works, we expect to publish the FPAR in October 2022, allowing the construction to commence for stage-1 from November 2022 onwards with commission readiness scheduled for December 2024. The stage-1 of the project is expected to reach completion by 31 March 2025.

The stage-2 construction works are scheduled to initiate by April 2027 and stage-2 is expected to reach completion by 31 March 2030.

7 Satisfaction of the RIT-D

In accordance with clause 5.17.4(j)(11)(iv) of the NER, we certify that the proposed option satisfies the regulatory investment test for distribution. The table below shows how each of these requirements have been met by the relevant section of this report.

Table 15: Compliance with regulatory requirements

Requirement	Section
5.17.4(j) The draft project assessment report must include the following:	
(1) a description of the identified need for the investment;	Section 3.
(2) the assumptions used in identifying the identified need (including, in the case of proposed reliability corrective action, reasons that the RIT-D proponent considers reliability corrective action is necessary);	Section 4.
(3) if applicable, a summary of, and commentary on, the submissions on the non-network options report;	No submissions were received.
(4) a description of each credible option assessed;	Section 5.
(5) where a Distribution Network Service Provider has quantified market benefits in accordance with clause 5.17.1(d), a quantification of each applicable market benefit for each credible option;	Section 6.4.
(6) a quantification of each applicable cost for each credible option, including a breakdown of operating and capital expenditure;	Sections 5 and 6.4.
(7) a detailed description of the methodologies used in quantifying each class of cost and market benefit;	Section 6.2.
(8) where relevant, the reasons why the RIT-D proponent has determined that a class or classes of market benefits or costs do not apply to a credible option;	Section 6.1.
(9) the results of a net present value analysis of each credible option and accompanying explanatory statements regarding the results;	Section 6.4.
(10) the identification of the proposed preferred option;	Section 1.1 and 6.5.
(11) for the proposed preferred option, the RIT-D proponent must provide:	
(i) details of the technical characteristics;	Appendix.
(ii) the estimated construction timetable and commissioning date (where relevant);	Section 6.6.
(iii) the indicative capital and operating cost (where relevant);	Section 6.6.
(iv) a statement and accompanying detailed analysis that the proposed preferred option satisfies the regulatory investment test for distribution; and	Section 7, including this table.

Service constraints at TT – Draft Project Assessment Report

Requirement	Section
(v) if the proposed preferred option is for reliability corrective action and that option has a proponent, the name of the proponent;	Not applicable.
(12) contact details for a suitably qualified staff member of the RIT-D proponent to whom queries on the draft report may be directed.	Section 1.3.
5.17.4(k) The RIT-D proponent must publish a request for submissions on the matters set out in the draft project assessment report, including the proposed preferred option, from:	
(1) Registered Participants, AEMO, non-network providers and interested parties; and	Section 1.3.
(2) if the RIT-D proponent is a Distribution Network Service Provider, persons on its demand side engagement register.	
5.17.4(l) If the proposed preferred option has the potential to, or is likely to, have an adverse impact on the quality of service experienced by consumers of electricity, including:	
(1) anticipated changes in voluntary load curtailment by consumers of electricity; or	
(2) anticipated changes in involuntary load shedding and customer interruptions caused by network outages, then the RIT-D proponent must consult directly with those affected customers in accordance with a process reasonably determined by the RIT-D proponent.	Not applicable.
5.17.4(m) The consultation period on the draft project assessment report must not be less than six weeks from the publication of the report.	Section 1.3.

Appendix – Technical Characteristics

Scope of works

The high level scope of work for the preferred option includes:

- Replace two existing 66kV bus tie circuit breakers.
- Install three new indoor 22kV modular switchboards with integral feeder protection, bus protection and capacitor protection and control configured as three 22kV buses with one transformer incomer, four 22kV feeders, one capacitor bank and two bus ties.
- Reconnect existing twelve 22kV feeders, three capacitor banks and three transformers to the indoor switchboards. Demolish and remove existing outdoor 22kV switchyard.
- Supply and install new 66kV bus and 66/22kV transformer protection schemes with new DC supplies to AusNet Services 125 Volt standard DC supply.
- Supply and install two new kiosk style station service transformers connected to selected feeders.
- Upgrade site fencing and security in accordance with latest risk ranking.
- Upgrade switchyard lighting, surfaces, drainage, trenches to current standards.